

## CONTENT MEASUREMENT SYSTEM

### FOR VENTILATED OR PRESSURISED TANKS

Castello offers a user-friendly way to represent the pressure measurement at the bottom of a tank as the quantity of remaining liquid. At the push of a button, the micro-controller performs the calculations using the information of the tank shape and dimensions and displays the remaining tank content quantity on the clearly legible 5-digit LED display in the desired unit (litres, gallons etc.).

The unit is configured using a PC and the easy-to-use software so that the filling level, which determines the pressure, can be converted into an appropriate filling quantity. First the tank shape is selected, then the tank dimensions and the specific gravity of the liquid are entered. It contains the most current tank shapes. The program covers the most common tank shapes, but also enables any shape by entering the parameters into a specified table.

The exclusive use of absolute pressure sensors in the Castello system eliminates the use of capillary vented cables with all the problems associated with a gauge pressure measurement. The Castello housing integrates an air pressure sensor, ranged between 0,8 bar and 1,2 bar absolute. The sensors to measure the hydrostatic pressure at the bottom of the tank are calibrated from 0,8 to 1,8 bar abs for tanks up to 5 m in height, and 0,8 to 2,3 bar abs for tanks up to 10 m in height. The pressure difference, calculated by the micro-controller, is the relative hydrostatic pressure.

The content of a pressurised tank is determined using the difference between the measurements from two absolute pressure sensors located at the top and bottom of the tank.

The overall accuracy of the system of 2 mbar is achieved using a computerised calibration and compensation procedure for the pressure sensors. The coefficients for this calculation are stored in EEPROMs in the sensors. These are retrieved by the microprocessor at each measurement and employed within the equations to calculate the pressure values. The Castello housing and hydrostatic sensor can be interchanged at will.

It is also possible to connect a standard 3-wire transmitter or high-precision digital transmitter (Series 36 X) that can be configured to an accuracy of 0,02 %FS over a range of 0 to 50 °C, a true representation of which is displayed by the Castello.

The power supply to the system (8 to 28 V) can be provided externally or internally using a 9 V battery. The display is obtained by pressing the button on the front, and the value appears for a configurable duration. The Castello has two switch outputs with configurable functionality and threshold values. An external power supply must be provided if the switch outputs are used.

## CASTELLO



CA1



Series 23 Q

Series 26 Q

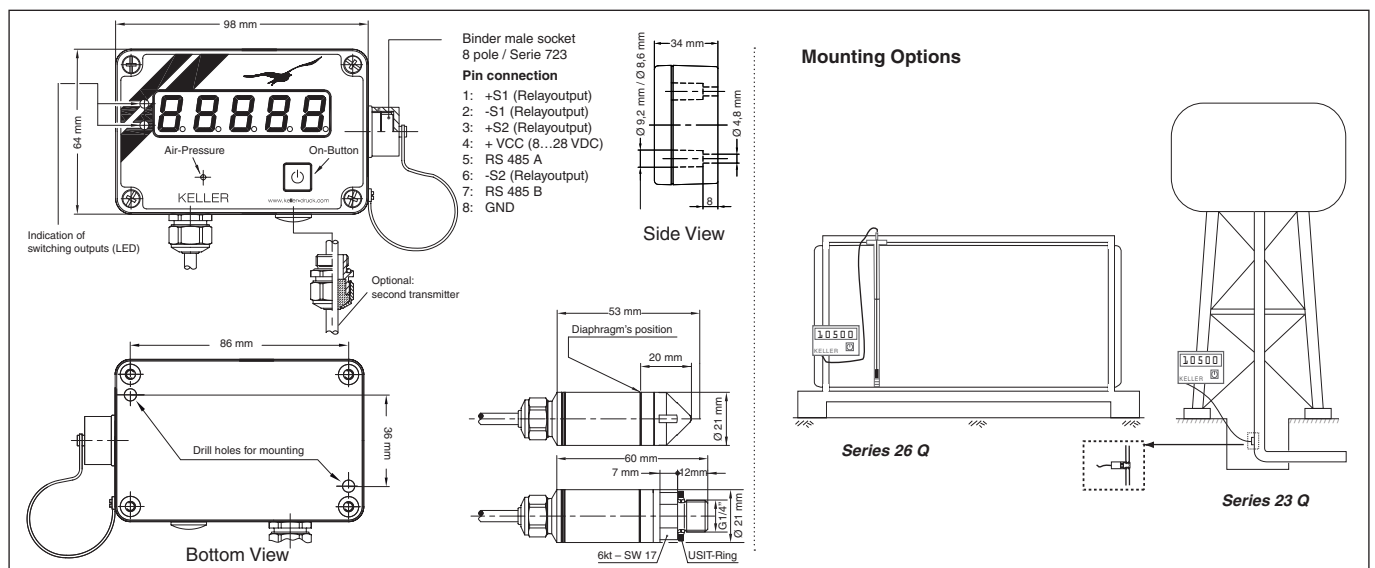

Subject to alterations

10/07



# KELLER

## Installation

There are two holes in the housing for mounting the unit. To install the sensor, unscrew and remove the cover of the unit, lead the cables through the PG screw connections and attach the wires to the screw terminals. The Castello is programmed via the connector on the side, which is also the location of the external power supply and switch output connections. Provided that the cover and the cable leadthrough are securely tightened, the extremely robust housing is watertight in compliance with IP65.

## Castello Ordering Information

Castello basic unit + KELLER standard transmitter series 23 Q (with thread) or series 26 Q (for filling level)  
+ converter K-107 (serial) or K-104B (USB) for configuration incl. adapter (5-pin --> 8-pin)  
or configuration in accordance with customer specifications

## Specifications for Castello

Measuring / Pressure Ranges 5 m tank level (10 m standard cable): Range 0,8...1,8 bar abs.  
10 m tank level (15 m standard cable): Range 0,8...2,3 bar abs.

Supply	External: 8...28 V Internal: 9 V battery	Indicator	5 digits – 14 mm high 7 segments LED
Switch outputs	2 pcs. PhotoMOS-Relais 40 V / 0,4 A	Resolution	Min. 2'000 Points
Battery Life	4'000 Measurements (display 10 seconds on) 6'000 Measurements (display 5 seconds on)	Indicator Material	Aluminium
Interface	RS485	Level Probe Material	Stainless Steel AISI 316L
Temperature Range	<u>Air Pressure Probe</u> -20...+70 °C <u>Level Probe</u> 0...50 °C	Cable Type	Hytrek, 4,60 mm Ø
Accuracy (Error Band)	max. 0,5 mbar    2 mbar (1,8 bar range) 3 mbar (2,3 bar range)	Probe Protection	IP 68
Overpressure	2 x Nominal Range	Indicator Protection	IP 65
		Probe Certification	II 1 G EEx ia IIC T6 LCIE 02 ATEX 6124 X
		Indicator Certification	In Progress

## Configuration PC-Software

The software to configure Castello can be downloaded from our website or ordered on CD for a handling charge. Castello can be connected to the PC via KELLER converter cable K-107 or K-104B with adapter. Castello can be configured for standard or EEPROM transmitters.

The software contains the pressure/content curves of the featured tanks. The dimensions of the tank of a certain shape and the specific gravity of the liquid is entered and the measurement unit for the display chosen.

The software also foresees the application for free standing water towers, where the distance of the tank to the position of the transducer can be chosen.

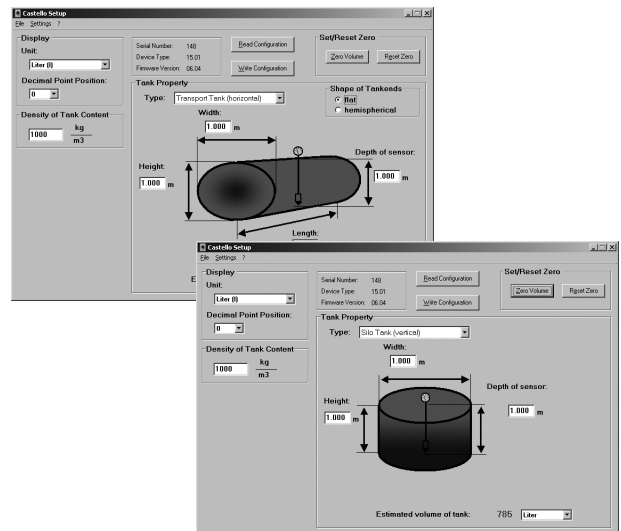

## Options (extra charge):

- Face plate with various measuring units and customer's logo
- Other housing colours (default: grey)
- Carrying case
- Factory configuration: foil strip on rear containing all application-related details
- Wireless transmission via GSM-1